

SEE SHEETS 2-4 FOR DETAILS



*NOTE: THIS PLAN DOES NOT INCLUDED ALL EASEMENTS AND RESTRICTIONS OVER THE SUBJECT LAND.

- 1. EASEMENT TO DRAIN WATER 1.5m wide MARKED (A) ON PLAN
- 2. EASEMENT FOR REPAIRS 0.9m wide MARKED (B) ON PLAN
- 3. EASEMENT FOR PAD MOUNT SUBSTATION 2.75 x 5.5; MARKED (REFER TO DIAGRAM) ON THE PLAN

| | | | | |
|---|---|---|--------------------|-----------------|
| <p>SURVEYOR: NAME: GROUP DEVELOPMENT SERVICES DATE OF SURVEY: -- SURVEYOR'S REF: --</p> | <p>PLAN OF SUBDIVISION Subdivision of Lot _ DP _ Services Location and Easements. 285-297 Annangrove Road, Box Hill</p> | <p>LGA: THE HILLS SHIRE LOCALITY: ROUSE HILL SUBDIVISION No.: Lengths are in metres. Reduction Ratio 1 : 2000</p> | <p>REGISTERED:</p> | <p>DP DRAFT</p> |
|---|---|---|--------------------|-----------------|

SEE

SHEET

3

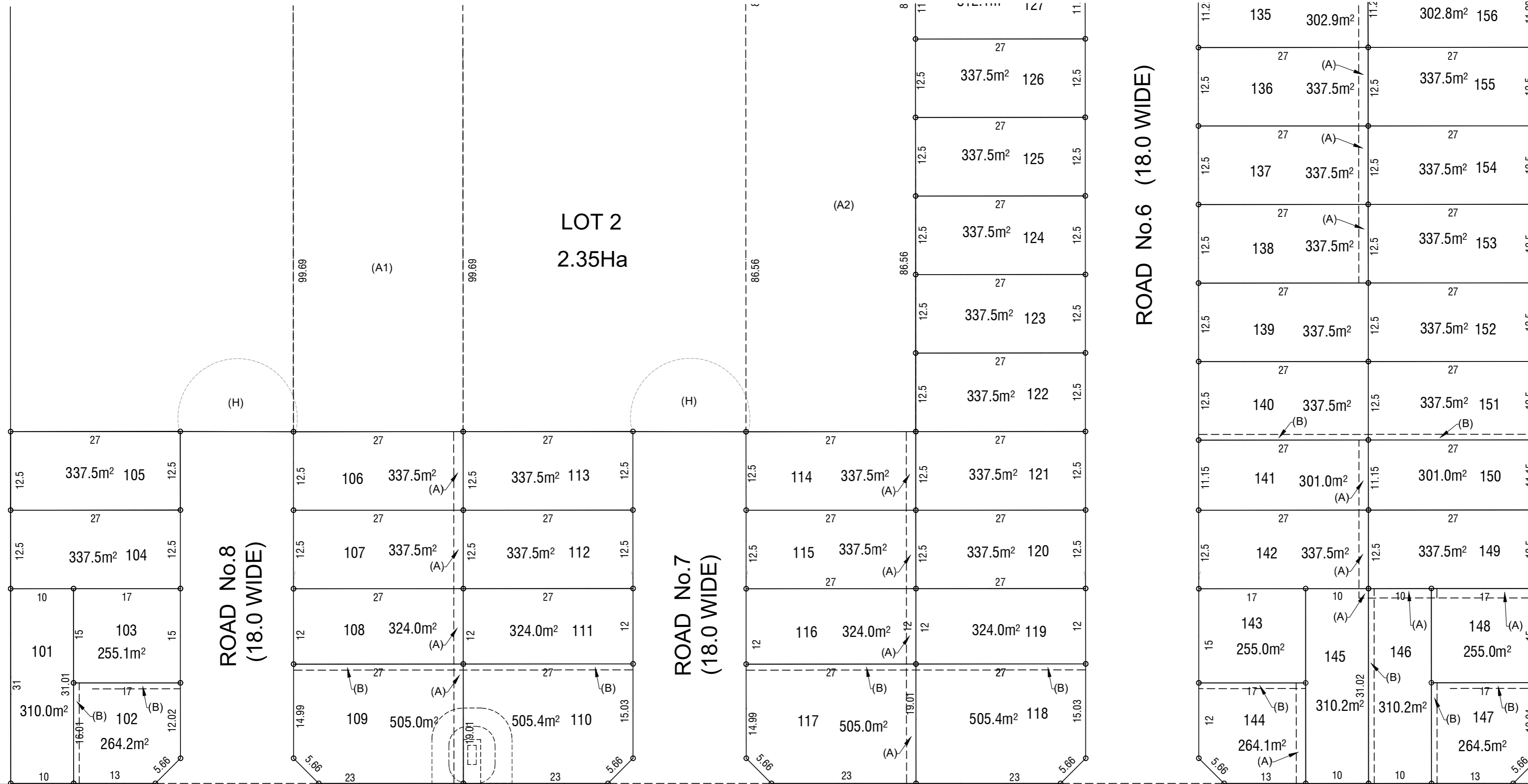

SEE DIAGRAM 'A'

PLATEAU AVENUE (19.0 WIDE)

ROAD No.6 (18.0 WIDE)

ROAD No.8 (18.0 WIDE)

ROAD No.7 (18.0 WIDE)

RAINFORST STREET (18.0 WIDE)

LOT 2
2.35Ha

LOT 109

LOT 110

PLATEAU AVENUE (19.0 WIDE)

DIAGRAM 'A'

SUBSTATION EASEMENT (1:200)

*NOTE: THIS PLAN DOES NOT INCLUDED ALL EASEMENTS AND RESTRICTIONS OVER THE SUBJECT LAND.

- (A) EASEMENT TO DRAIN WATER 1.5m wide
- (B) EASEMENT FOR REPAIRS 0.9m wide
- (C) EASEMENT FOR ELECTRICITY CABLES 1m wide
- (D) EASEMENT FOR ACCESS Variable Width
- (E) EASEMENT FOR EASEMENT FOR PAD MOUNT SUBSTATION 2.75 x 5.5
- (F) RESTRICTION ON USE OF LAND (In relation to fire rating of buildings)
- (G) RESTRICTION ON USE OF LAND (In relation to swimming pools)

SURVEYOR:
 NAME: GROUP DEVELOPMENT SERVICES
 DATE OF SURVEY: --
 SURVEYOR'S REF: --

PLAN OF SUBDIVISION
 Subdivision of Lot _ DP _
 Services Location and Easements.
 285-297 Annangrove Road, Box Hill

LGA: THE HILLS SHIRE
 LOCALITY: ROUSE HILL
 SUBDIVISION No.:

REGISTERED:

DP DRAFT

Lengths are in metres. Reduction Ratio 1 : 500

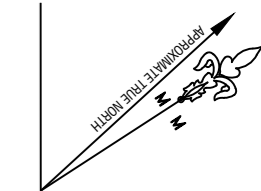

SEE

SHEET

4

GRANDHILL PARKWAY (19.6 WIDE)

RAINFOREST STREET (18.0 WIDE)

SEE (H)
DIAGRAM 'C'

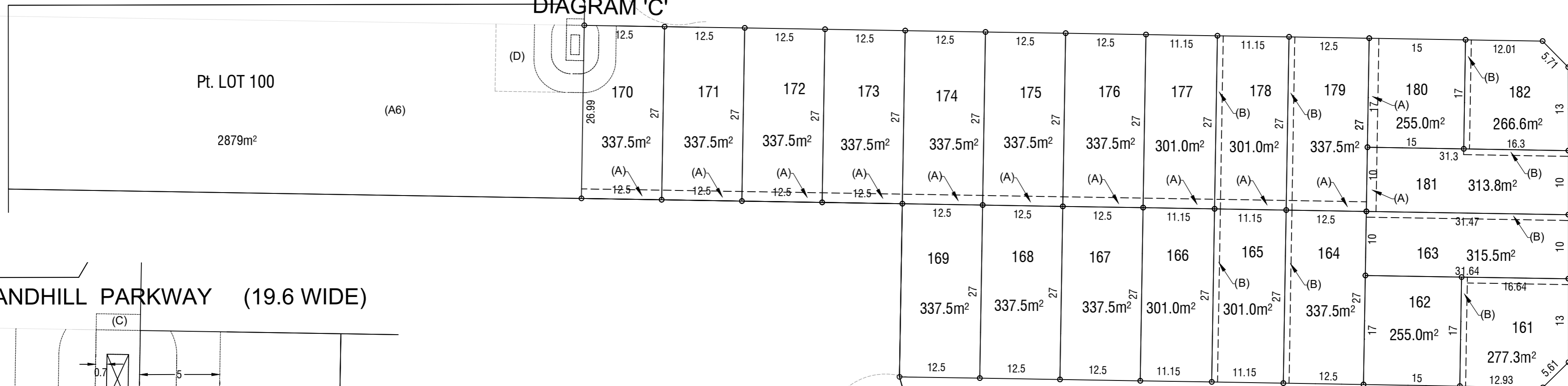

GRANDHILL PARKWAY (19.6 WIDE)

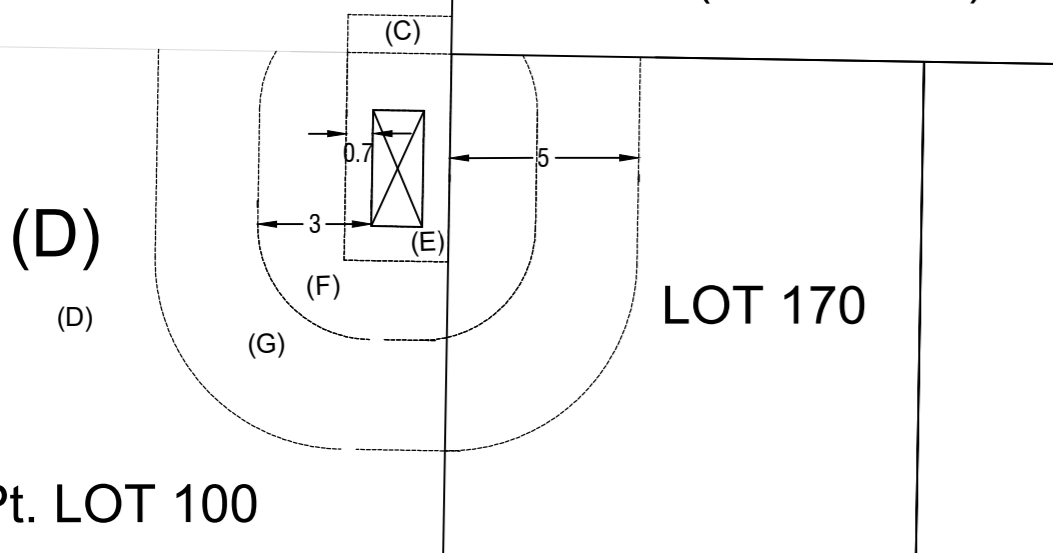

Pt. LOT 100

DIAGRAM 'C'
SUBSTATION EASEMENT (1:200)

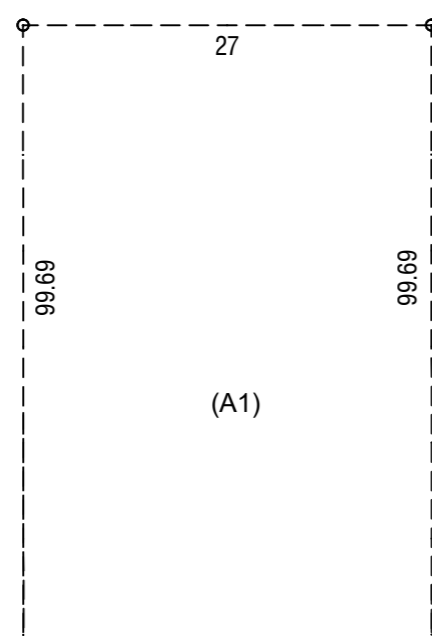

SEE

SEE (H)
DIAGRAM 'B'

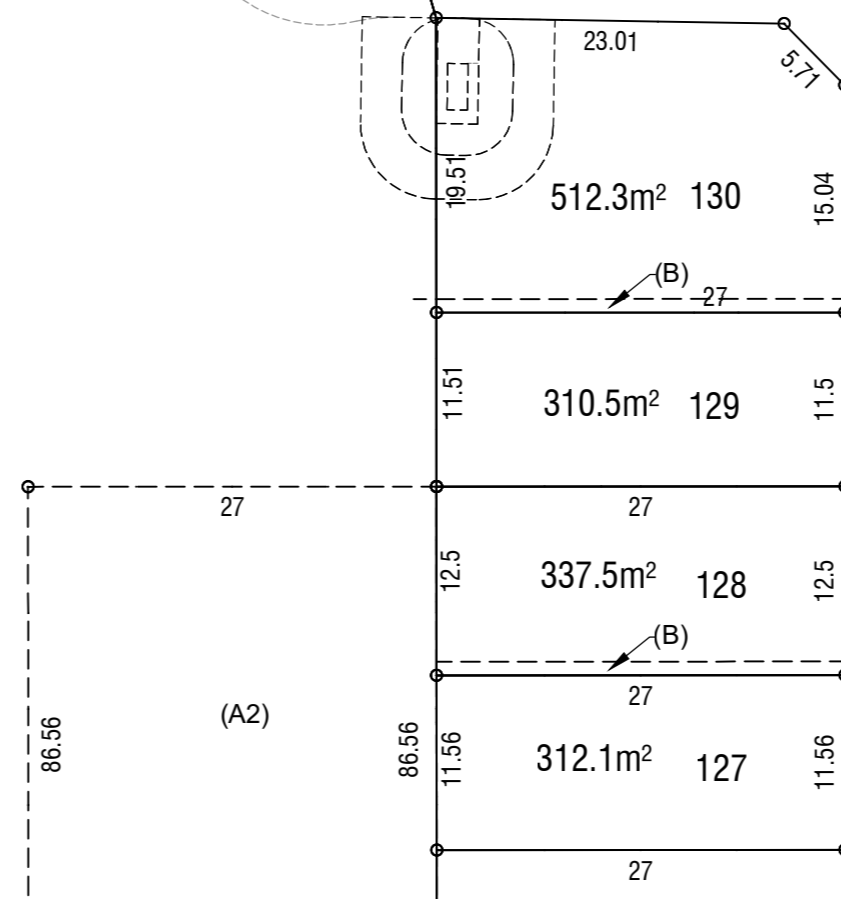

SHEET

ROAD No.5 (18.0 WIDE)

ROAD No.6 (18.0 WIDE)

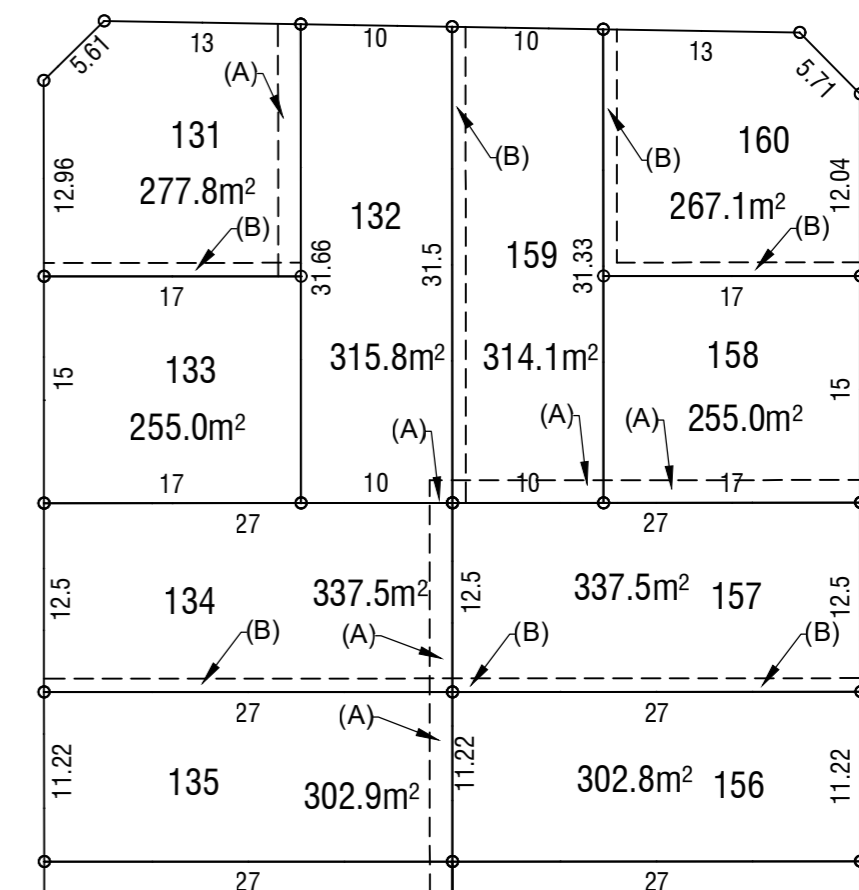

2

*NOTE: THIS PLAN DOES NOT INCLUDED ALL EASEMENTS AND RESTRICTIONS OVER THE SUBJECT LAND.

- (A) EASEMENT TO DRAIN WATER 1.5m wide
- (B) EASEMENT FOR REPAIRS 0.9m wide
- (C) EASEMENT FOR ELECTRICITY CABLES 1m wide
- (D) EASEMENT FOR ACCESS Variable Width
- (E) EASEMENT FOR EASEMENT FOR PAD MOUNT SUBSTATION 2.75 x 5.5
- (F) RESTRICTION ON USE OF LAND (In relation to fire rating of buildings)
- (G) RESTRICTION ON USE OF LAND (In relation to swimming pools)

ROAD No.5 (18.0 WIDE)

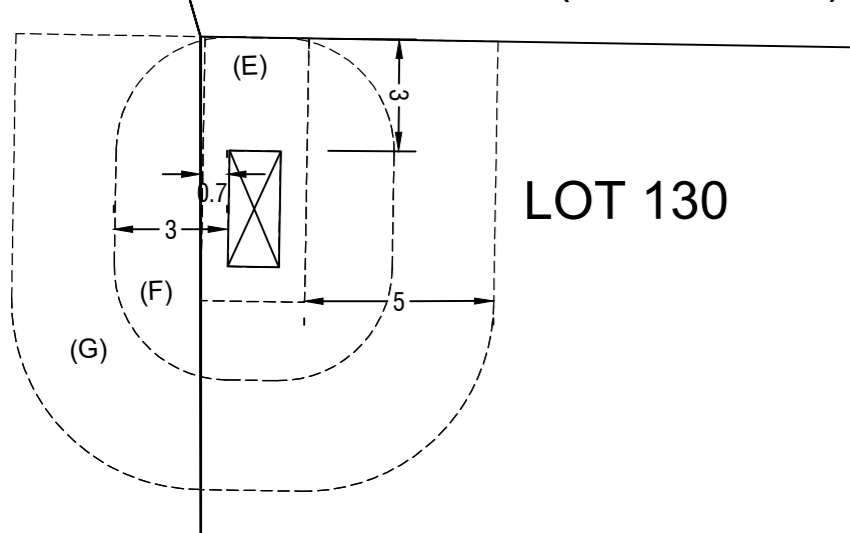

DIAGRAM 'B'
SUBSTATION EASEMENT (1:200)

SURVEYOR:
NAME: GROUP DEVELOPMENT SERVICES
DATE OF SURVEY: --
SURVEYOR'S REF: --

PLAN OF SUBDIVISION
Subdivision of Lot _ DP _
Services Location and Easements.
285-297 Annangrove Road, Box Hill

LGA: THE HILLS SHIRE
LOCALITY: ROUSE HILL
SUBDIVISION No.:
Lengths are in metres. Reduction Ratio 1 : 500

REGISTERED:

DP DRAFT

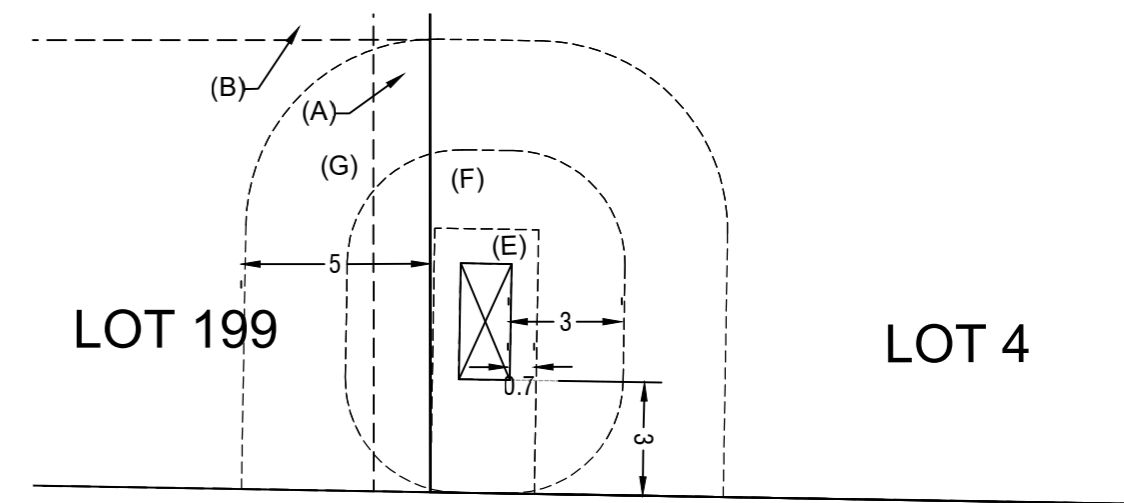
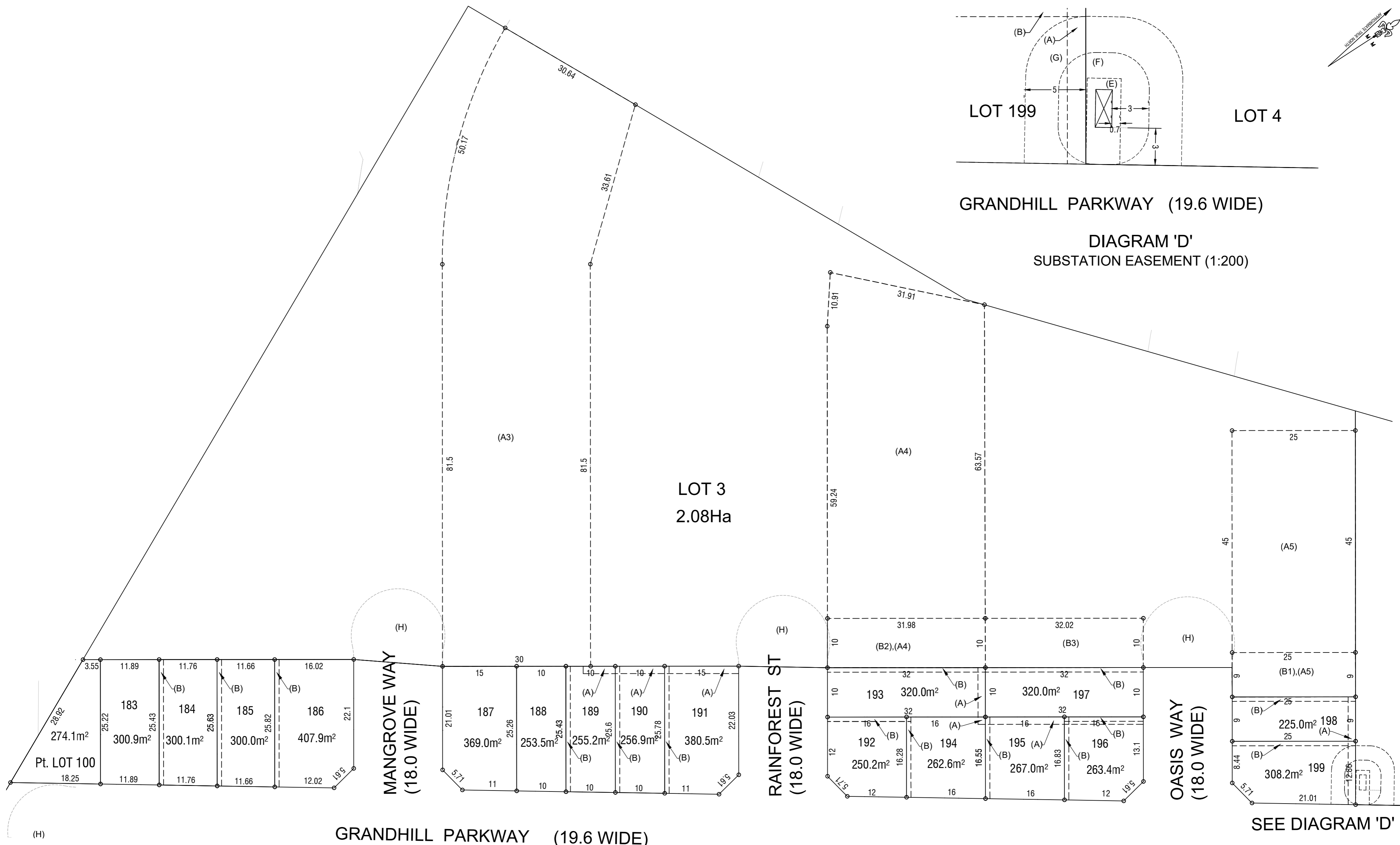
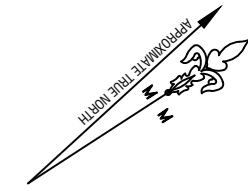

GRANDHILL PARKWAY (19.6 WIDE)

DIAGRAM 'D'
SUBSTATION EASEMENT (1:200)

SEE

GRANDHILL PARKWAY (19.6 WIDE)

SHEET

3

SEE DIAGRAM 'D'

*NOTE: THIS PLAN DOES NOT INCLUDED ALL EASEMENTS AND RESTRICTIONS OVER THE SUBJECT LAND.

- (A) EASEMENT TO DRAIN WATER 1.5m wide
- (B) EASEMENT FOR REPAIRS 0.9m wide
- (C) EASEMENT FOR ELECTRICITY CABLES 1m wide
- (D) EASEMENT FOR ACCESS Variable Width
- (E) EASEMENT FOR EASEMENT FOR PAD MOUNT SUBSTATION 2.75 x 5.5
- (F) RESTRICTION ON USE OF LAND (In relation to fire rating of buildings)
- (G) RESTRICTION ON USE OF LAND (In relation to swimming pools)

SURVEYOR:
 NAME: GROUP DEVELOPMENT SERVICES
 DATE OF SURVEY: --
 SURVEYOR'S REF: --

PLAN OF SUBDIVISION
 Subdivision of Lot _ DP _
 Services Location and Easements.
 285-297 Annangrove Road, Box Hill

LGA: THE HILLS SHIRE
 LOCALITY: ROUSE HILL
 SUBDIVISION No.:
 Lengths are in metres. Reduction Ratio 1 : 500

REGISTERED:

DP DRAFT